

Lightem 10G XFP Duplex LC Transceiver 1310nm Singlemode 2km LXFPS1302-LR

FEATURES

- Up to 11.1Gbps Data Links
- Maximum link length of 2km on SMF
- Power dissipation < 2.0W
- 1310nm DFB transmitter, PIN photo-detector
- Metal enclosure, for lower EMI
- Integrated Digital Diagnostic monitoring
- No Reference Clock required
- Compliant with SFP+ MSA with LC connector
- Single 3.3V power supply
- Operating Range: 0°C to 70°C Operating temperature



APPLICATIONS

- 10GBASE-SR/SW 10G Ethernet
- 1200-Mx-SN-I 10G Fiber Channel

ABSOLUTE MAXIMUM RATINGS

Parameter	Symbol	Min.	Typ.	Max.	Unit	Note
Storage Temperature	Ts	-40	-	85	°C	
Relative Humidity	RH	5	-	95	%	
Power Supply Voltage	VCC	-0.3	-	+3.6	V	
Signal Input Voltage		Vcc-0.3	-	Vcc+0.3	V	

ELECTRICAL CHARACTERISTICS

Parameter	Symbol	Min	Typ	Max	Unit	Note
Supply Voltage	Vcc3	3.13		3.45	V	
Supply Current	Icc3			250	mA	
Module total power	p			0.8	W	1
Receiver						
Differential data output swing	Vout. pp	340	650	850	mV	2
Data output rise time	t _r			38	ps	3
Data output fall time	t _f			38	ps	3
LOS Fault	VLOS fault	Vcc -0.5		VccHost	V	4
LOS Normal	VLOS norm	GND		GND+0.5	V	4

- Notes:
1. Maximum total power value is specified across the full temperature and voltage range.
 2. After internal AC coupling.
 3. Or open circuit.
 4. Into 100 ohms differential termination.
 5. These are unfiltered 20-80% values
 6. Loss Of Signal is open collector to be pulled up with a 4.7k – 10kohm resistor to 3.15 – 3.6V. Logic 0 indicates normal operation; logic 1 indicates no signal detected.

TELECOM/DATACOM SYSTEM

OPTICAL CHARACTERISTICS

Parameter	Symbol	Min	Typ	Max	Unit	Note
Transmitter						
Average Launch Power	POUT	-6		0.5	dBm	1
Optical Wavelength	λ	1260		1350	nm	
Optical Extinction Ratio	ER	6.0			dB	
Output Eye Mask	Compliant with IEEE 802.3aq					
Receiver						
Receiver Sensitivity	Sen			-15	dBm	2
Input Saturation Power (Overload)	Psat	0.5			dBm	
Wavelength Range	λ_C	1270		1610	nm	
LOS De -Assert	LOSD			-17	dBm	
LOS Assert	LOSA	-28			dBm	
LOS Hysteresis		0.5			dB	
Maximum Supported Distance						
SMF	Lmax			10	km	

Notes:

1. Average power figures are informative only, per IEEE802.3aq
2. Conditions of stressed receiver tests per IEEE802.3aq.

PIN DESCRIPTION

Pin	Symbol	Symbol	Name /Description	NOTE
1		GND	Module Ground	1
2		VEE5	Optional -5.2 Power Supply – Not required	
3	LVTTTL-I	Mod-Desel	Module De-select; When held low allows the module to respond to 2-wire serial interface commands	
4	LVTTTL-O	Interrupt	Interrupt (bar); Indicates presence of an important condition which can be read over the serial 2-wire interface	2
5	LVTTTL-I	TX_DIS	Transmitter Disable; Transmitter laser source turned off	
6		VCC5	+5 Power Supply – Not required	
7		GND	Module Ground	1
8		VCC3	+3.3V Power Supply	
9		VCC3	+3.3V Power Supply	
10	LVTTTL-I	SCL	Serial 2-wire interface clock	
11	LVTTTL-I/O	SDA	Serial 2-wire interface data line	2
12	LVTTTL-O	Mod_Abs	Module Absent; Indicates module is not present. Grounded in the module.	2
13	LVTTTL-O	Mod_NR	Module Not Ready; XGIGA's defines it as a logical OR between RX_LOS and Loss of Lock in TX/RX.	2
14	LVTTTL-O	RX_LOS	Receiver Loss of Signal indicator	2
15		GND	Module Ground	1
16		GND	Module Ground	1
17	CML-O	RD-	Receiver inverted data output	
18	CML-O	RD+	Receiver non-inverted data output	
19		GND	Module Ground	1

TELECOM/DATACOM SYSTEM

20	VCC2		+1.8V Power Supply – Not required	
21	LVTTTL-I	P_Down/RST	Power Down; When high, places the module in the low power stand-by mode and on the falling edge of P_Down initiates a module reset	
			Reset; The falling edge initiates a complete reset of the module including the 2-wire serial interface, equivalent to a power cycle.	
22	VCC2		+1.8V Power Supply – Not required	
23	GND		Module Ground	1
24	PECL-I	RefCLK+	Reference Clock non-inverted input, AC coupled on the host board – Not required	3
25	PECL-I	RefCLK-	Reference Clock inverted input, AC coupled on the host board – Not required	3
26	GND		Module Ground	1
27	GND		Module Ground	1
28	CML-I	TD-	Transmitter inverted data input	
29	CML-I	TD+	Transmitter non-inverted data input	
30	GND		Module Ground	1

Notes:

1. Module circuit ground is isolated from module chassis ground within the module.
2. Open collector; should be pulled up with 4.7kΩ – 10kΩ on host board to a voltage between 3.15V and 3.6V.
3. A Reference Clock input is not required by the XGXF-1396-10D. If present, it will be ignored.

PIN OUT OF CONNECTOR BLACK ON HOST BOARD

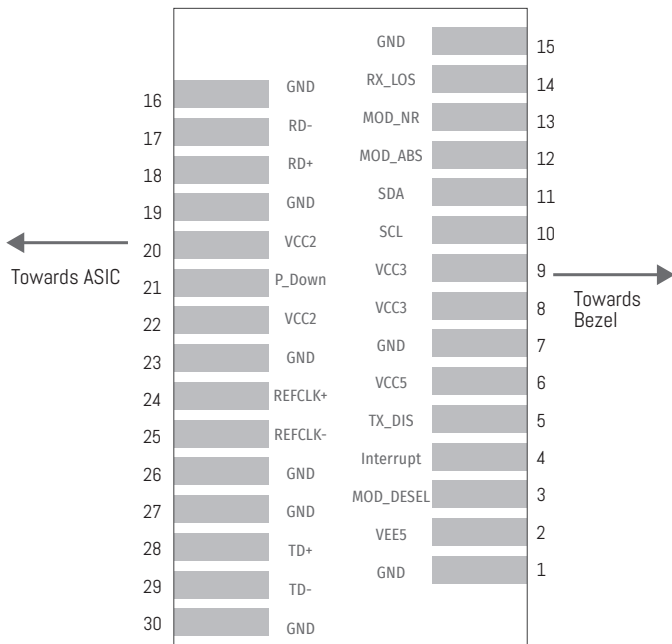
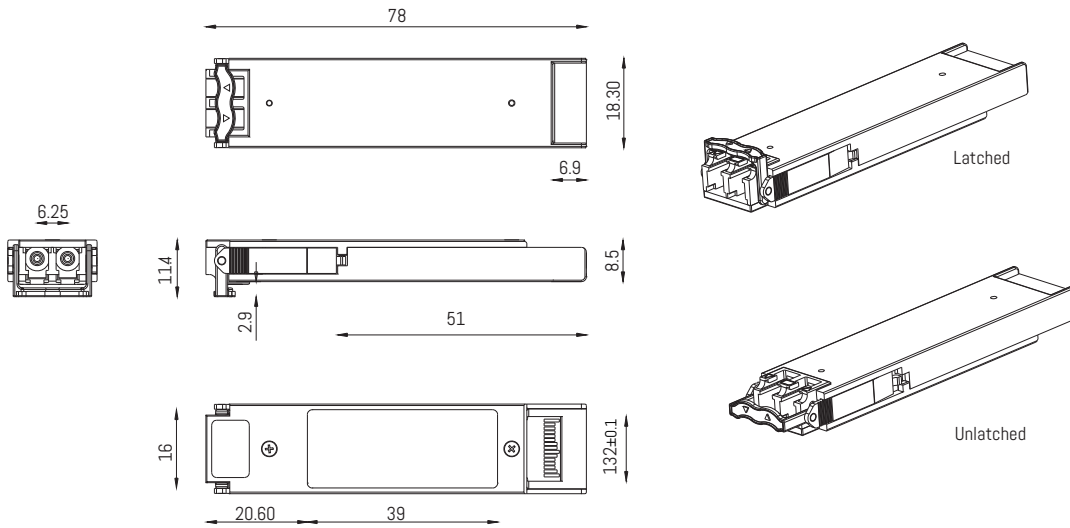

Diagram of Host Board Connector Block Pin Numbers and Name

TELECOM/DATACOM SYSTEM

MECHANICAL DIMENSIONS



ORDERING INFORMATION

PN

LXFPS1302-LR Lightem 10G XFP Duplex LC SM 1310nm 2km