

Lightem 10G CWDM XFP Duplex LC Transceiver 40km LXFPSCWxx40

FEATURES

- Up to 11.1Gbps Data Links
- Maximum link length of 40km on SMF
- Power dissipation < 2.5W
- Cooled CWDM EML transmitter (1470-1610nm), PIN photo-detector
- Metal enclosure, for lower EMI
- 2-wire interface with integrated Digital Diagnostic monitoring
- Hot-pluggable XFP footprint
- Standard Operating Range: 0°C to 70°C Operating temperature
- Optional Industrial grade: -40°C to 85°C Operating temperature



APPLICATIONS

- 10GBASE-ER
- 10G SONET/SDH, OTU2/2e

ABSOLUTE MAXIMUM RATINGS

Parameter	Symbol	Min.	Typ.	Max.	Unit	Note
Storage Temperature	Ts	-40	-	85	°C	
Case Operating Temperature	TCase	-5	-	+70	°C	
	TCase	-40	-	+85	°C	
	RH	5	-	95	%	
Relative Humidity	VCC	-0.3	-	+4	V	
Power Supply Voltage		Vcc-0.3	-	Vcc+0.3	V	

TELECOM/DATACOM SYSTEM

ELECTRICAL CHARACTERISTICS

Parameter	Symbol	Min	Typ	Max	Unit	Note
Supply Voltage 1.8v supply	Vcc2	1.71		1.89	V	
Supply Voltage 3.3v supply	Vcc3	3.13		3.47	V	
Supply Current 1.8v Supply	Icc2			180	mA	
Supply Current 3.3v Supply	Icc3			640	mA	
Module total power	p		100	2.5	W	1
Transmitter						
Industrial differential impedance	RIN	120			Ω	2
Differential data input swing	Vin, pp	2.0		820	mV	
Transmit disable voltage	VD	GND		Vcc	V	3
Transmit enable voltage	Ven			GND+0.8	V	
Transmit disable assert time				10	us	
Receiver						
Differential data out swing	Vout, pp	340	650	850	mV	4
Data output rise time	tr			38	ps	5
Data output fall time	tf			38	ps	5
LOS Fault	VLOS fault	Vcc - 0.5		Vcc Host	V	6
LOS Normal	VLOS norm	GND		GND+0.5	V	6

Notes:

1. Maximum total power value is specified across the full temperature and voltage range.
2. After internal AC coupling.
3. Or open circuit.
4. Into 100 ohms differential termination.
5. These are unfiltered 20-80% values
6. Loss Of Signal is open collector to be pulled up with a 4.7k – 10kohm resistor to 3.15 – 3.6V. Logic 0 indicates normal operation; logic 1 indicates no signal detected.

OPTICAL CHARACTERISTICS

Parameter	Symbol	Min	Typ	Max	Unit	Note
Transmitter						
Average Launch Power	POUT	-1		4	dBm	1
Optical Wavelength	λ	1470		1610	nm	
Optical Extinction Ratio	ER	8.2			dB	
Output Eye Mask		Compliant with IEEE 802.3aq				
Receiver						
Receiver Sensitivity	Sen			-16.5	dBm	2
Input Saturation Power (Overload)	Psat	0.5			dBm	
Wavelength Range	λC	1270		1610	nm	
LOS De -Assert	LOSD			-18	dBm	
LOS Assert	LOSA	-32			dBm	
LOS Hysteresis		0.5				

Notes:

1. Average power figures are informative only, per IEEE802.3aq
2. Conditions of stressed receiver tests per IEEE802.3aq.

TELECOM/DATACOM SYSTEM

PIN DESCRIPTION

Pin	Symbol	Symbol	Name /Description	NOTE
1		GND	Module Ground	1
2		VEE5	Optional -5.2 Power Supply – Not required	
3	LVTTTL-I	Mod-Desel	Module De-select; When held low allows the module to respond to 2-wire serial interface commands	
4	LVTTTL-O	Interrupt	Interrupt (bar); Indicates presence of an important condition which can be read over the serial 2-wire interface	2
5	LVTTTL-I	TX_DIS	Transmitter Disable; Transmitter laser source turned off	
6		VCC5	+5 Power Supply – Not required	
7		GND	Module Ground	1
8		VCC3	+3.3V Power Supply	
9		VCC3	+3.3V Power Supply	
10	LVTTTL-I	SCL	Serial 2-wire interface clock	
11	LVTTTL-I/O	SDA	Serial 2-wire interface data line	2
12	LVTTTL-O	Mod_Abs	Module Absent; Indicates module is not present. Grounded in the module.	2
13	LVTTTL-O	Mod_NR	Module Not Ready; XGIGA's defines it as a logical OR between RX_LOS and Loss of Lock in TX/RX.	2
14	LVTTTL-O	RX_LOS	Receiver Loss of Signal indicator	2
15		GND	Module Ground	1
16		GND	Module Ground	1
17	CML-O	RD-	Receiver inverted data output	
18	CML-O	RD+	Receiver non-inverted data output	
19		GND	Module Ground	1
20		VCC2	+1.8V Power Supply – Not required	
21	LVTTTL-I	P_Down/RST	Power Down; When high, places the module in the low power stand-by mode and on the falling edge of P_Down initiates a module reset Reset; The falling edge initiates a complete reset of the module including the 2-wire serial interface, equivalent to a power cycle.	
22		VCC2	+1.8V Power Supply – Not required	
23		GND	Module Ground	1
24	PECL-I	RefCLK+	Reference Clock non-inverted input, AC coupled on the host board – Not required	3
25	PECL-I	RefCLK-	Reference Clock inverted input, AC coupled on the host board – Not required	3
26		GND	Module Ground	1
27		GND	Module Ground	1
28	CML-I	TD-	Transmitter inverted data input	
29	CML-I	TD+	Transmitter non-inverted data input	
30		GND	Module Ground	1

Notes:

1. Module circuit ground is isolated from module chassis ground within the module.
2. Open collector; should be pulled up with 4.7kΩ – 10kΩ on host board to a voltage between 3.15V and 3.6V.
3. A Reference Clock input is not required by the XGXF-1396-10D. If present, it will be ignored.

TELECOM/DATACOM SYSTEM

PIN OUT OF CONNECTOR BLACK ON HOST BOARD

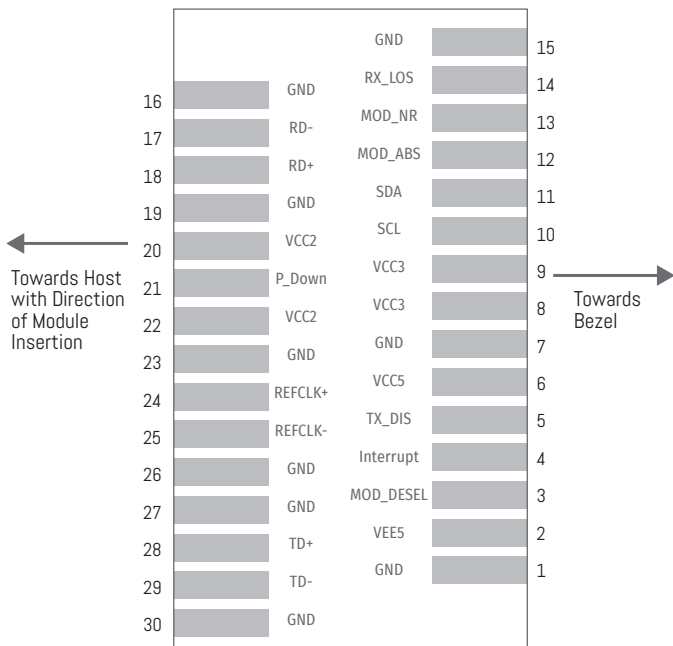
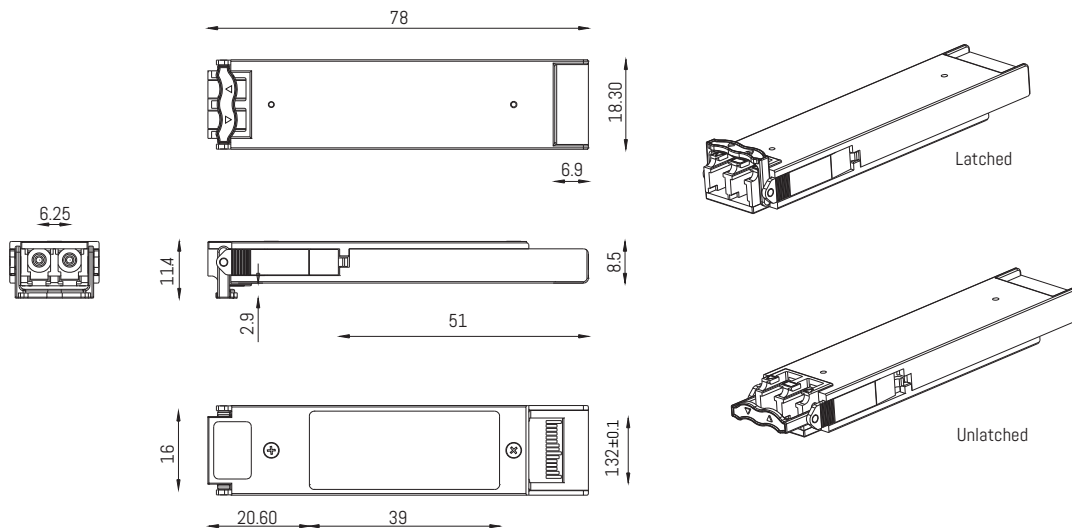

Diagram of Host Board Connector Block Pin Numbers and Name

MECHANICAL DIMENSIONS



ORDERING INFORMATION

PN	Description				
LXFPSCWxx40-x	Lightem 10G CWDM XFP Duplex LC SM 1xx0nm 40km				
xx- wavelength	47- 1470nm	49- 1490nm	51- 1510nm	53- 1530nm	55- 1550nm
	57- 1570nm	59- 1590nm	61- 1610nm		
x-	l:	optional industrial grade			