

## Lightem 10G DWDM 100GHz XFP Duplex LC Transceiver 40km LXFPSDW100xxx40

### FEATURES

- 100GHz channel spacing DWDM
- Up to 11.1Gbps Data Links
- Maximum link length of 40km on SMF
- Power dissipation < 2.5W
- Cooled DWDM EML transmitter (100GHz), PIN photo-detector
- Metal enclosure, for lower EMI
- 2-wire interface with integrated Digital Diagnostic monitoring
- Hot-pluggable XFP footprint
- No Reference Clock required
- Single 3.3V power supply
- Standard Operating Range: 0°C to 70°C Operating temperature
- Optional Industrial grade: -40°C to 85°C Operating temperature



### APPLICATIONS

- 10GBASE-ER
- 10G SONET/SDH, OTU2/2e

### ABSOLUTE MAXIMUM RATINGS

Parameter	Symbol	Min.	Typ.	Max.	Unit	Note
Storage Temperature	Ts	-40	-	85	°C	
Relative Humidity	RH	5	-	95	%	
Power Supply Voltage	VCC	-0.3	-	+4	V	
Signal Input Voltage		Vcc-0.3	-	Vcc+0.3	V	

### RECOMMENDED OPERATING CONDITIONS

Parameter	Symbol	Min.	Typ.	Max.	Unit	Note
Case Operating Temperature	Tcase	-5	-	+70	°C	Commercial grade
	Tcase	-40	-	+85	°C	Industrial grade
Power Supply Voltage	VCC	3.14	3.3	3.47	V	
Power Supply Current	ICC	-	-	640	mA	
Data Rate	BR		10.3125		Gbps	
Transmission Distance	TD		-	40	km	
Coupled Fiber			Singlemode Fiber			SMF

# TELECOM/DATACOM SYSTEM

## ELECTRICAL CHARACTERISTICS

Parameter	Symbol	Min	Typ	Max	Unit	Note
Supply Voltage 1.8v supply	Vcc2	1.71		1.89	V	
Supply Voltage 3.3v supply	Vcc3	3.13		3.47	V	
Supply Current 1.8v Supply	Icc2			180	mA	
Supply Current 3.3v Supply	Icc3			640	mA	
Module total power	P			2.5	W	1
<b>Transmitter</b>						
Input differential impedance	RIN		100		$\Omega$	2
Differential data input swing	V <sub>in</sub> , pp	120		820	mV	
Transmit disable voltage	VD	2.0		Vcc	V	3
Transmit enable volatage	V <sub>en</sub>	GND		GND+0.8	V	
<b>Receiver</b>						
Differential data out swing	V <sub>out</sub> , pp	3.40	650	850	mV	4
LOS Fault	VLOS fault	Vcc - 0.5		Vcc Host	V	5
LOS Normal	VLOS norm	GND		GND+0.5	V	5

- Notes:
1. Maximum total power value is specified across the full temperature and voltage range.
  2. After internal AC coupling.
  3. Or open circuit.
  4. Into 100 ohms differential termination.
  5. Loss Of Signal is open collector to be pulled up with a 4.7k – 10kohm resistor to 3.15 – 3.6V. Logic 0 indicates normal operation; logic 1 indicates no signal detected.

## OPTICAL CHARACTERISTICS

Parameter	Symbol	Min	Typ	Max	Unit	Note
<b>Transmitter</b>						
Average Launch Power	POUT	-1		4	dBm	1
Optical Wavelength	$\lambda_c$	$\lambda_c-0.1$		$\lambda_c+0.1$	nm	
Optical Wavelength Spacing			100		GHz	
Optical Extinction Ratio	ER	8.2			dB	
Output Eye Mask		Compliant with IEEE 802.3aq				
<b>Receiver</b>						
Receiver Sensitivity				-16.5	dBm	2
Input Saturation Power (Overload)	Sen	0.5			dBm	
Wavelength Range	Psat	1260		1610	nm	
LOS De -Assert	$\lambda_C$			-18	dBm	
LOS Assert	LOSD	-32			dBm	
LOS Hysteresis		0.5			dB	

- Notes:
1. Corresponds to approximately 04 nm.
  2. Measured with BER<10<sup>-12</sup>@10.3Gbps, 231 – 1 PRBS..

# TELECOM/DATACOM SYSTEM

## PIN DESCRIPTION

Pin	Symbol	Symbol	Name /Description	NOTE
1		GND	Module Ground	1
2		VEE5	Optional -5.2 Power Supply – Not required	
3	LVTTTL-I	Mod-Desel	Module De-select; When held low allows the module to respond to 2-wire serial interface commands	
4	LVTTTL-O	Interrupt	Interrupt (bar); Indicates presence of an important condition which can be read over the serial 2-wire interface	2
5	LVTTTL-I	TX_DIS	Transmitter Disable; Transmitter laser source turned off	
6		VCC5	+5 Power Supply – Not required	
7		GND	Module Ground	1
8		VCC3	+3.3V Power Supply	
9		VCC3	+3.3V Power Supply	
10	LVTTTL-I	SCL	Serial 2-wire interface clock	
11	LVTTTL-I/O	SDA	Serial 2-wire interface data line	2
12	LVTTTL-O	Mod_Abs	Module Absent; Indicates module is not present. Grounded in the module.	2
13	LVTTTL-O	Mod_NR	Module Not Ready; XGIGA's defines it as a logical OR between RX_LOS and Loss of Lock in TX/RX.	2
14	LVTTTL-O	RX_LOS	Receiver Loss of Signal indicator	2
15		GND	Module Ground	1
16		GND	Module Ground	1
17	CML-O	RD-	Receiver inverted data output	
18	CML-O	RD+	Receiver non-inverted data output	
19		GND	Module Ground	1
20		VCC2	+1.8V Power Supply – Not required	
21	LVTTTL-I	P_Down/RST	Power Down; When high, places the module in the low power stand-by mode and on the falling edge of P_Down initiates a module reset Reset; The falling edge initiates a complete reset of the module including the 2-wire serial interface, equivalent to a power cycle.	
22		VCC2	+1.8V Power Supply – Not required	
23		GND	Module Ground	1
24	PECL-I	RefCLK+	Reference Clock non-inverted input, AC coupled on the host board – Not required	3
25	PECL-I	RefCLK-	Reference Clock inverted input, AC coupled on the host board – Not required	3
26		GND	Module Ground	1
27		GND	Module Ground	1
28	CML-I	TD-	Transmitter inverted data input	
29	CML-I	TD+	Transmitter non-inverted data input	
30		GND	Module Ground	1

### Notes:

1. Module circuit ground is isolated from module chassis ground within the module.
2. Open collector; should be pulled up with 4.7kΩ – 10kΩ on host board to a voltage between 3.15V and 3.6V.
3. A Reference Clock input is not required by the XGXF-1396-10D. If present, it will be ignored.

# TELECOM/DATACOM SYSTEM

## PIN OUT OF CONNECTOR BLACK ON HOST BOARD

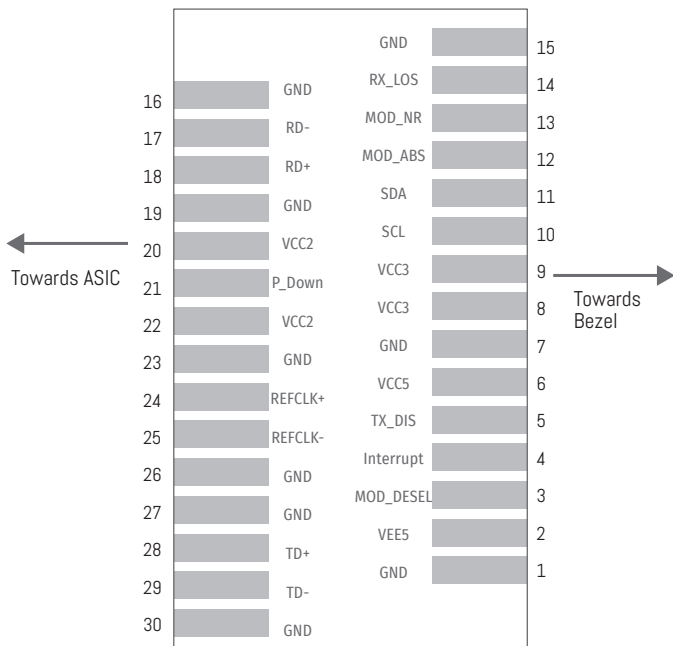
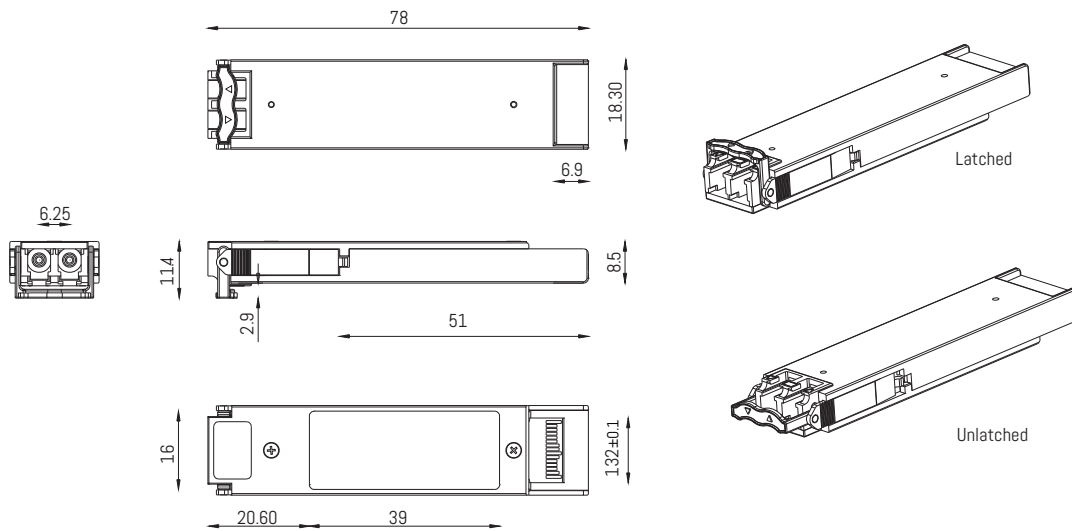

Diagram of Host Board Connector Block Pin Numbers and Name

## MECHANICAL DIMENSIONS



# TELECOM/DATACOM SYSTEM

## CHANNEL SELECTION

Channel	Wavelength(nm)	Frequency (THz)	Channel	Wavelength(nm)	Frequency (THz)
C17	1563.86	191.70	C39	1546.12	193.90
C18	1563.05	191.80	C40	1545.32	194.00
C19	1562.23	191.90	C41	1544.53	194.10
C20	1561.42	192.00	C42	1543.73	194.20
C21	1560.61	192.10	C43	1542.94	194.30
C22	1559.79	192.20	C44	1542.14	194.40
C23	1558.98	192.30	C45	1541.35	194.50
C24	1558.17	192.40	C46	1540.56	194.60
C25	1557.36	192.50	C47	1539.77	194.70
C26	1556.55	192.60	C48	1538.98	194.80
C27	1555.75	192.70	C49	1538.19	194.90
C28	1554.94	192.80	C50	1537.40	195.00
C29	1554.13	192.90	C51	1536.61	195.10
C30	1553.33	193.00	C52	1535.82	195.20
C31	1552.52	193.10	C53	1535.04	195.30
C32	1551.72	193.20	C54	1534.25	195.40
C33	1550.92	193.30	C55	1533.47	195.50
C34	1550.12	193.40	C56	1532.68	195.60
C35	1549.32	193.50	C57	1531.90	195.70
C36	1548.51	193.60	C58	1531.12	195.80
C37	1547.72	193.70	C59	1530.33	195.90
C38	1546.92	193.80	C60	1529.55	196.00
Non ITU	Peak wavelength between 1528.77nm-1563.86		C61	1528.77	196.10

## ORDERING INFORMATION

PN	
LXFPSDW100xxx40-x	Lightem 10G DWDM 100GHz XFP Duplex LC SM Chxx 40km
xxx-	Channel
	- C17-C61
x-	I- optional industrial grade
eg LXFPSDW100C3740-I	Lightem 10G DWDM 100GHz XFP Duplex LC SM Ch37 40km Industrial grade